

NORRIS AP500 15amp

code: 90-200

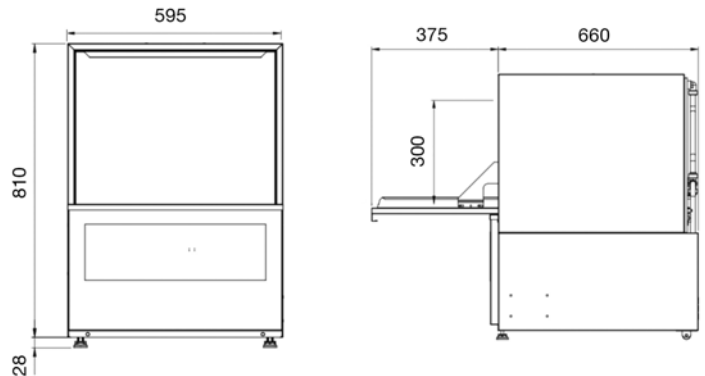

FEATURES

- **Warranty** – years parts and labour, 5 years on the cabinet & control board (see p.28 for conditions & extended warranty offer)
- Compact underbench dishwasher suited for cafes and restaurants.
- Made tough in our factory in Caves Beach NSW
 - Robust 304 Stainless steel hand made cabinet
 - Heating Boiler made from Stainless steel 316
 - Stainless steel wash and rinse arms
 - Large 304 Stainless Steel Filters / Scrap Trays
- **Connects to cold water: back to back 1 min cycles**
- Reliable German electrical contactors
- Reliable European heating elements made from the Incoloy® 825, highly resistant to corrosion and cracking so the elements last longer
- Recirculating wash system
- Cleans 600 plates per hour
- 1, 2 & 5 minute cycle options
- 15 Amp power connection
- Automatic detergent and rinse aid injection
- Rear rollers for easy machine inspection
- Rinse temperature controlled by thermostop function for sanitation compliance
- Useable wash height 300mm
- Double skinned door reducing heat and noise pollution
- Standard drain pump for easy installation
- Easy servicing access for minimal disruption

INCLUSIONS

- 1 x Flat rack insert 500mm x 500mm
- 1 x Plate rack insert 500mm x 500mm
- 1 x Cutlery container
- 1 x Water connection hose
- 2 x Chemical weights & filters
- 2 x Adjustable & 2 x Roller feet
- 1 x Operating manual

TECHNICAL DATA

Height	
Cabinet	810 mm
Cabinet inc. legs	838 mm
Usable Wash	300 mm
Width	
Cabinet	595 mm
Depth	
Cabinet	660 mm
With door open	1035 mm
Capacities	
Loads/Hour	up to 45*
Water per Cycle	2.5L**
Wash Pump	370W
Wash Tank Litres	18
Boiler Tank Litres	6
Element (wash)	3000W
Element (boiler)	3600W
Detergent Injection	yes
Rinse Aid Injection	yes
Temperatures	
Wash Degrees C	65 °C
Rinse Degrees C	88 °C
Plumbing	
Drain Water	Pump out ½" BSP (cold)
Electrical	
Volts/Hz	240V AC/50Hz
Max. Amp. load	15amps
Note: this machine has load shedding capability	

* Subject to incoming water temperature 20°C

** Subject to incoming water pressure



Water pressure requirements are: 10L/min at 200-400 kPa max.