

GAS GRIDDLE WITH SMOOTH PLATE ON OPEN CUPBOARD

CODE
CR0995959

MODEL
D96/10FTTG

SERIE
DIAMANTE90

Project:

Rev.:

Zone:

Location:



we innovate cooking



GENERAL FEATURES

- As well as offering a vast range of solutions and 2 mm thick, 90 cm deep worktops with burners up to 10 kW, the series has all the power, robustness and functionality you need to work effectively.
- • AISI 304 stainless steel, Scotch Brite finish
- • Swing door with accessories for holding knives, ladles and bottles
- • Digital control panel with waterproof control knobs
- • Double doors: bottom or side hung
- • Functional side panels with up to 7 containers and holders
- • The modular range: 200-400-600-800-1200
- • Simple, functional coupling system
- • Also available in a plinth-mounted version
- • Wide range of accessories

TECHNICAL DATA

- GAS GRIDDLE WITH SMOOTH PLATE ON OPEN CUPBOARD
- Outer casing and feet in stainless steel. Adjustable worktop height, ranging from 840 to 900 mm. Recessed hot plate, 40 mm lower than worktop surface. Enamelled hot plate surface, with hard polished chrome plating, available in smooth, ribbed or mixed finish versions. Plate slants 10mm forwards. Large grease drawer. Gas model: burner with self-stabilizing flame. Temperature adjustment and regulation with safety tap and thermocouple (200-400°C) or thermostat safety valve with thermocouple (110-280°C).
- IPX5 protection against water splashes.

GAS GRIDDLE WITH SMOOTH PLATE ON OPEN CUPBOARD



we innovate cooking

CODE
CR0995959

MODEL
D96/10FTTG

SERIE
DIAMANTE90

TECHNICAL INFORMATION

SPECIFICATIONS	DATA
CODE	CR0995959
DEFINITION	D96/10 FTTG FRY TOP GAS L M120 V.G.TERM.
MODEL	D96/10 FTTG
SUPPLY	GAS
DEPTH	1200 MM
WIDTH	900 MM
HEIGHT	870 MM
NET WEIGHT	152,000
VOLUME	0,940 M3
PACKAGING LENGTH	1260,000
PACKAGING WIDTH	1020,000
PACKAGING HEIGHT	1150,000
PACKAGING VOLUME	1,478
PACKAGING GROSS WEIGHT	180,000
GAS TYPE	GPL 28-30/37 mbar
GAS POWER (G30/30 MBAR)	31,50 KW
GAS POWER (G25/25 MBAR)	30,00 KW
CERTIFIED MODEL	D96/10 FTTG
CERTIFICATION NUMBER	CE-0085BS0203
POT GAS TOT / POT FRIGO2	31,50
CERTIFICATION	0085BS0203
CERTIFICATION BODY	0085
TYPE	A GIORNO
PRODUCT VARIANTS	PIASTRA RIGATA
NUMBER OF MODULES	1/1 MODULO

GAS GRIDDLE WITH SMOOTH PLATE ON OPEN CUPBOARD



we innovate cooking

CODE
CR0995959

MODEL
D96/10FTTG

SERIE
DIAMANTE90

ACCESSOIRES

CODE	MODEL	DESCRIPTION
CR0985249	90XFTP4	BACKSPALSH FOR FRY TOP MOD. 400
CR0985259	90XFTP6	BACKSPALSH FOR FRY TOP MOD. 600
CR0985269	90XFTP8	BACKSPALSH FOR FRY TOP MOD. 800
CR0957610	90XFTP12	BACKSPALSH FOR FRY TOP MOD. 1200
CR0592079	NXFTC4	CLEANING DRAWER FOR FRY TOP
CR0592089	NXFTC6/8	CLEANING DRAWER FOR FRY TOP
CR0592060	NXFTT	TAP FOR FRY TOP PLATE CLEANING
CR0996979	DBVP4	DOOR M40
CR0997009	DBVPA4	ACCESSORIBABLE DOOR M40
CR0997029	DAPC	KNIFE HOLDER
CR0997019	DAPD	DOSATOR HOLDER
CR0997039	DAPS	SPICE RACK
CR0997049	DAPM	LADLE HOLDER
CR0997059	DAPDB	DISPENCER HOLDER
CR1353589	DBVC4	DRAWERS KIT
CR0592809	NXZF12	FRONTAL PLINTH
CR0592830	NX9ZG	PLINTH JUNCTION
CR0592820	NX9ZL	LATERAL PLINTH
MA97432000	NXR	CASTORS KIT
MA97433000	NXRI	CASTORS KIT
CR0592869	CR0592869	KIT 4 FEET FOR CONCRETE PLINTH INSTALLATION
CR0593580	NX9PT	KIT 4 FEET FOR TOP VERSION
CR0592879	CR0592879	KIT ANTI-TIPPING FEET
CR0592399	NXTVT1	CLOSING PANEL FOR TECHNICAL SPACE
CR0592409	NXTVT2	CLOSING PANEL FOR TECHNICAL SPACE
PTD9DX	PTD9DX	SIDE DIAMANTE PANEL RIGHT
PTD9SX	PTD9SX	SIDE DIAMANTE PANEL LEFT
CMF0912	CMF0912	FRONTAL HANDRAIL
CMA1812	CMA1812	PERIMETRAL HANDRAIL

GAS GRIDDLE WITH SMOOTH PLATE ON OPEN CUPBOARD

CODE
CR0995959

MODEL
D96/10FTTG

SERIE
DIAMANTE90



*we*innovate cooking

we cook with
Diamante

Product's PLUS



The plates tilt 10 mm towards the front of the appliance, optimising flow of fat into the drip drawer.



Plate welded to hob, thus guaranteeing a wider cooking zone and preventing the accumulation of dirt.

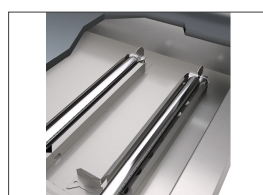

Multiple burners underneath the plate ensure uniform heat distribution.



Thanks to the IPX5 water jet ingress protection rating, awarded after passing specific tests, knobs and knob bezels can be washed at the end of the working day without affecting performance or safety.

Olis Ali Group S.r.l.

Via Del Boscon, 424 - 32100 Belluno - Italy

W: olis.it M: info@olis.it

T: +39 0437 8558

F: +39 0437 838 274



GAS GRIDDLE WITH SMOOTH PLATE ON OPEN CUPBOARD



we innovate cooking

CODE
CR0995959

MODEL
D96/10FTTG

SERIE
DIAMANTE90

SCHEMA DI INSTALLAZIONE - INSTALLATION DIAGRAM - INSTALLATIONSPLAN - SCHÉMA D'INSTALLATION - ESQUEMA DE INSTALACION -INSTALLATIESCHEMA - IINSTALLATIONSRITNINGAR

MISURE IN cm - DIMENSIONS IN cm - ABMESSUNGEN IN cm
MESURES EN cm - MEDIDAS EN cm - MATEN IN cm

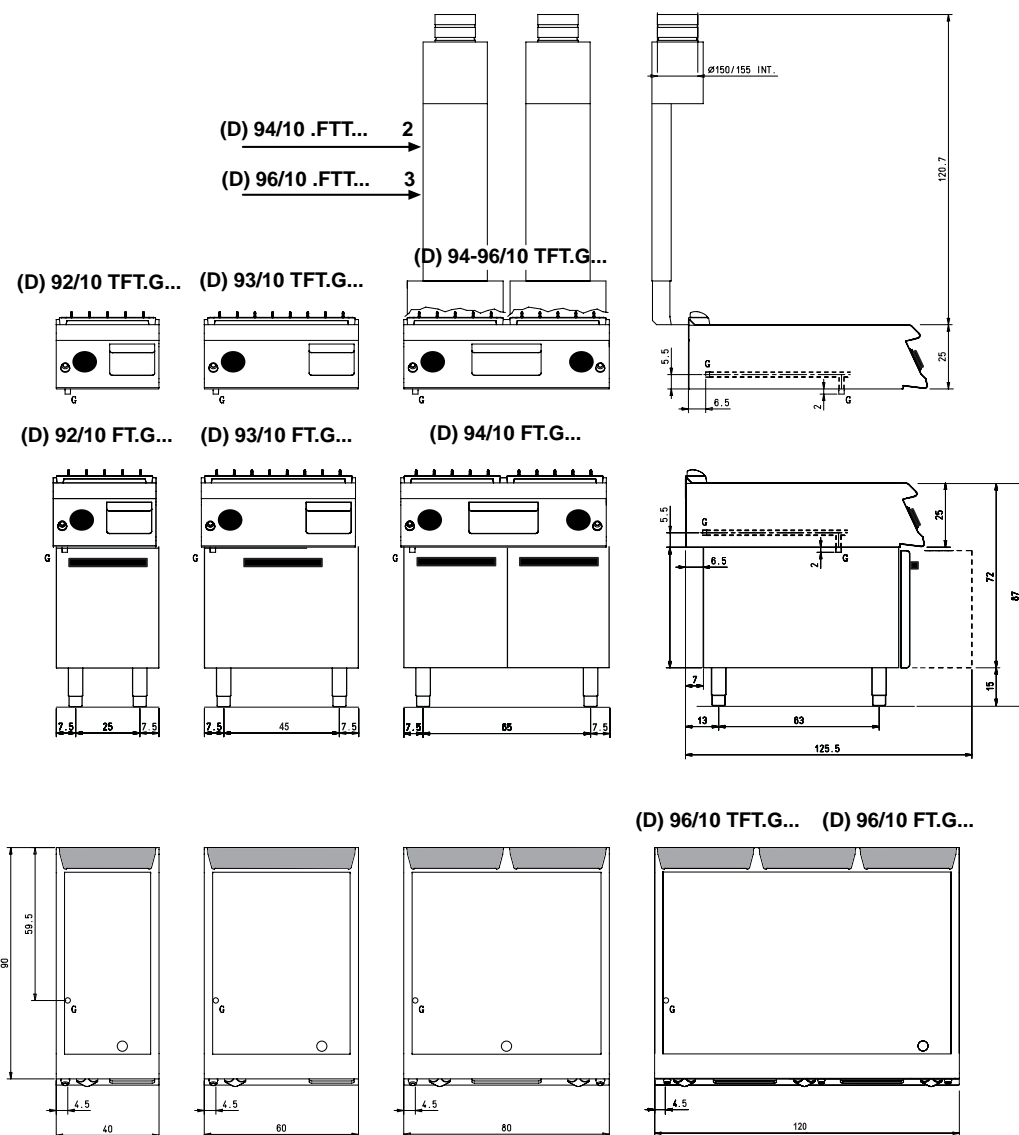

Legenda - Legende - Key - Légende - Leyenda - Legenda

G Attacco arrivo gas - Gasanschluss - Gas connection
Arrivée gaz - Union de gas - Gasaansluiting
EN 10226-1 R 1/2; EN ISO 228-1 G 1/2 (DK)