

HE1USSBA

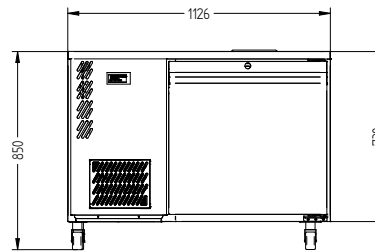

CATEGORY	FOODSERVICE COUNTERS
RANGE	Emerald
UNIT	REFRIGERATOR
TYPE	SELF CONTAINED
DOORS	1

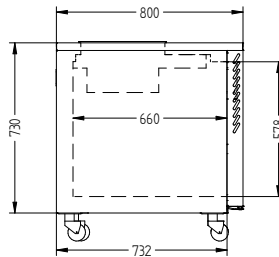
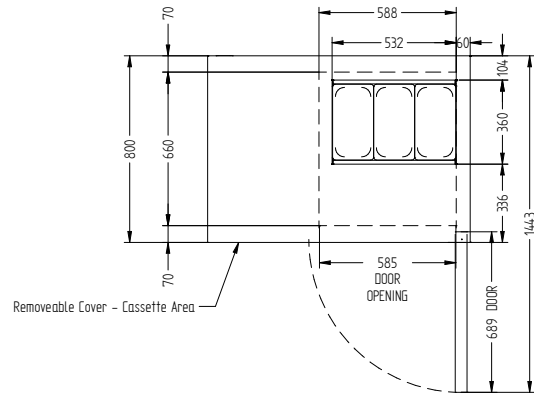
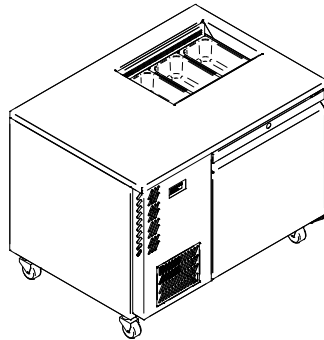

SPECIFICATIONS

CAPACITY LITRES	310
TEMPERATURE	1°C / 4°C
FRONT BREATHING	YES
DIMENSIONS - W X D X H (ON 120MM H CASTORS) MM	1126 W x 800 D x 850 H
WEIGHT UNPACKED (KG)	120

STANDARD INCLUSIONS ***

DOOR TYPE	Standard: SD (Solid Door) Optional: DR (Drawer)
FINISH (INTERIOR AND EXTERIOR EXCLUDING REAR AND UNDER)	SS (Stainless Steel)
SHELVES/DOOR	1
BLOWN AIRWELL (100MM DEEP 1/3 PANS INCLUDED)	3 X 1/3 PANS

ELECTRICAL

POWER SUPPLY	10 amp	
BLOWN AIRWELL MODELS	RUNNING AMPS	3.6

GAS TYPE

REFRIGERANT	FRIDGE MODELS	R134a
-------------	---------------	-------

*** For **OPTIONS** refer to the current Williams Price Guide