

HS2SS

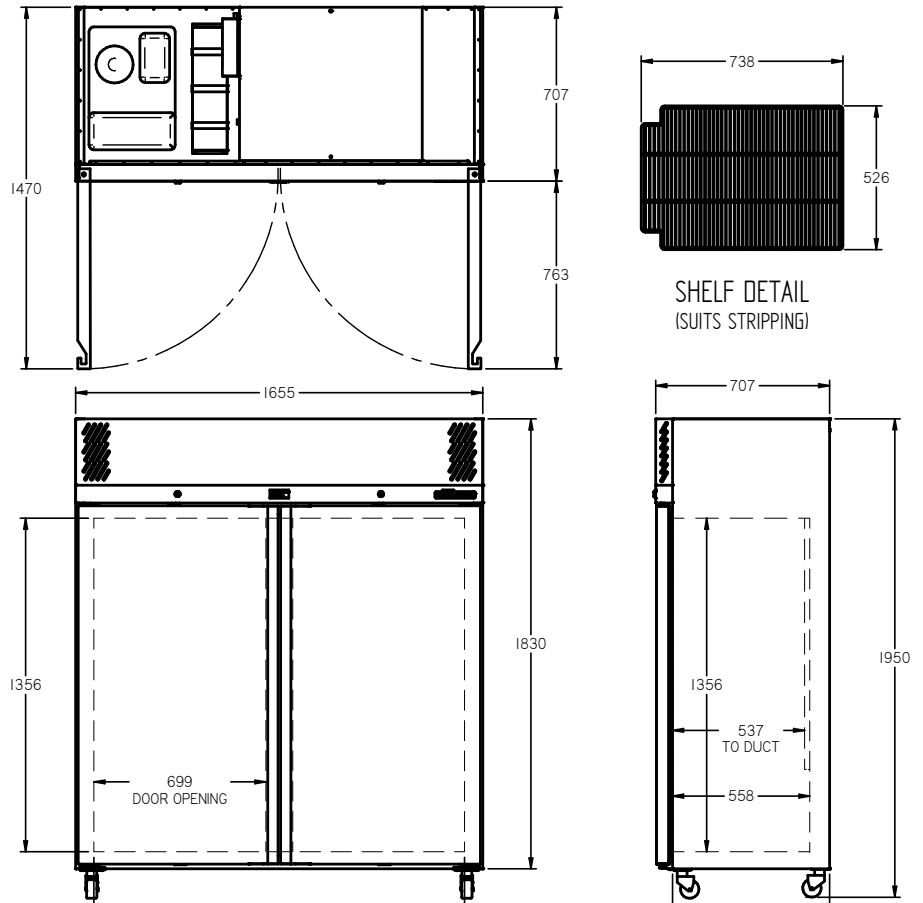

CATEGORY	FOODSERVICE UPRIGHTS
RANGE	Sapphire
UNIT	REFRIGERATOR
TYPE	SELF CONTAINED
DOORS	2

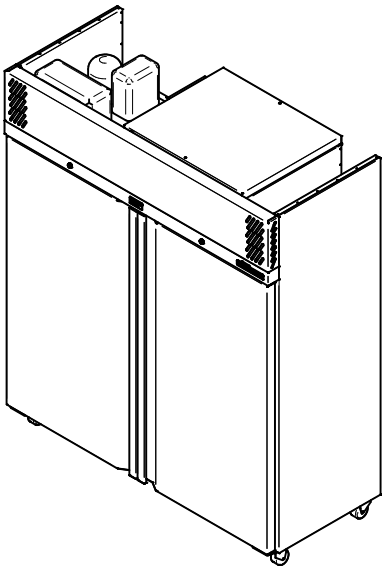

SPECIFICATIONS

CAPACITY LITRES	1270
TEMPERATURE	1°C / 4°C
DIMENSIONS - W X D X H (ON 120 MM H CASTORS) MM	1655 W x 707 D x 1950 H
WEIGHT UNPACKED (KG)	220

STANDARD INCLUSIONS ***

DOOR TYPE	S (Solid Door), Optional: PT (Pass Through), HD (Half Door)
FINISH (INTERIOR AND EXTERIOR EXCLUDING REAR AND UNDER)	S (Stainless Steel)
SHELVES/DOOR (ADJUSTABLE STRIPS AND CLIPS)	4
GAS TYPE	
REFRIGERANT	R134a

ELECTRICAL

POWER SUPPLY	10 amp
POWER CABLE LENGTH (METRES)	2
RUNNING AMPS	3.8

PERFORMANCE

KWH/24HR READING	5.3
TEST STANDARD	EN 16825 (Professional)
TEST CONDITIONS	4 M1
AMBIENT RATING	43°C

REFRIGERATION WATTAGES FOR OPTIONAL REMOTE UNITS

FRIDGE MODELS - SOLID DOORS (R404A)	670 @ -5°C SST
-------------------------------------	----------------

*** For **OPTIONS** refer to the current Williams Price Guide