

LD2G

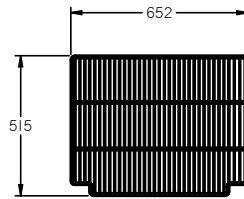

CATEGORY	GENERAL UPRIGHTS
RANGE	Diamond
UNIT	FREEZER
TYPE	SELF CONTAINED
DOORS	2



SHELF DETAIL

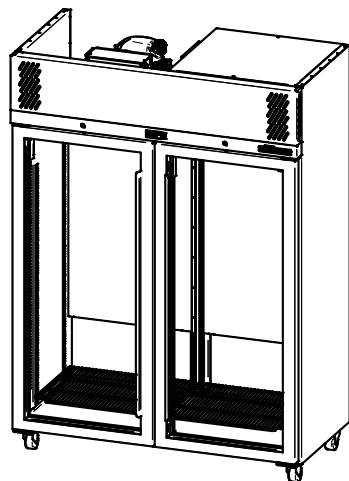
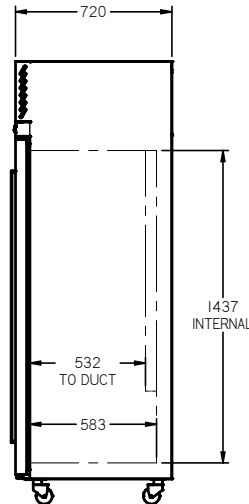
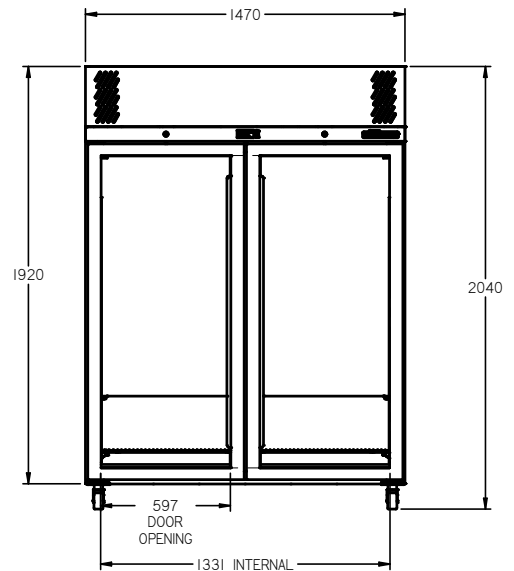
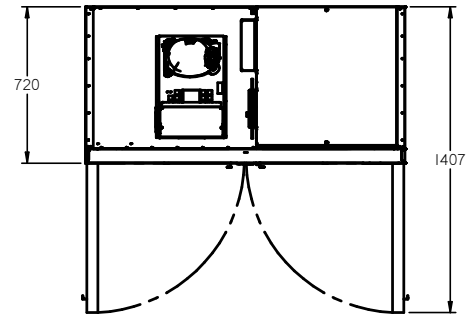

SPECIFICATIONS

CAPACITY LITRES	1100
TEMPERATURE	-18°C / -22°C
DIMENSIONS - W X D X H (ON 120 MM H CASTORS) MM	1470 W x 720 D x 2040 H
WEIGHT UNPACKED (KG)	250

STANDARD INCLUSIONS ***

DOOR TYPE	G (Glass Door)
FINISH (INTERIOR AND EXTERIOR EXCLUDING REAR AND UNDER)	W (White), B (Black), S (Stainless Steel)
SHELVES/DOOR (ADJUSTABLE STRIPS AND CLIPS)	4

GAS TYPE

REFRIGERANT	R404a
-------------	-------

ELECTRICAL

POWER SUPPLY	10 amp
POWER CABLE LENGTH (METRES)	2
RUNNING AMPS	8.5

PERFORMANCE

KWH/24H READING	33.3
TEST STANDARD	ISO 23953 (Display)
TEST CONDITIONS	3 L1
AMBIENT RATING	38°C

REFRIGERATION WATTAGES FOR OPTIONAL REMOTE UNITS

FREEZER MODELS - GLASS DOORS (R404A)	1650 @ -30°C SST
--------------------------------------	------------------

*** For **OPTIONS** refer to the current Williams Price Guide