

# GC25UGDSL

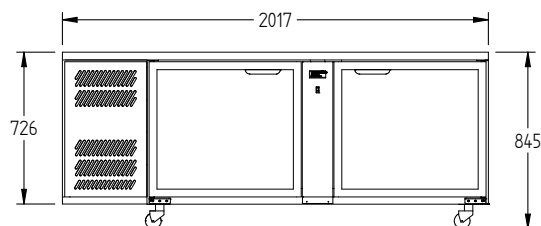

CATEGORY	GENERAL COUNTERS & BACK BARS
RANGE	<b>Glass Chiller</b>
UNIT	REFRIGERATOR
TYPE	SELF CONTAINED
DOORS	2

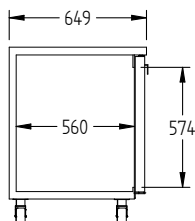
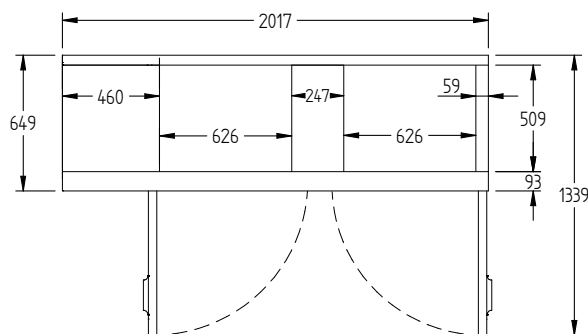

## SPECIFICATIONS

<b>CAPACITY - BASKET/DOOR (NOT INCLUDED)(500 X 500 BASKET)</b>	4 Baskets
<b>TEMPERATURE</b>	1°C / 4°C
<b>SPRING LOAD</b>	YES
<b>DIMENSIONS - W X D X H (ON CASTORS) MM</b>	2017 W x 649 D x 845 H
<b>WEIGHT UNPACKED (KG)</b>	140

## STANDARD INCLUSIONS \*\*\*

<b>DOOR TYPE</b>	Standard: GD (Glass Door)
<b>FINISH (INTERIOR AND EXTERIOR EXCLUDING REAR AND UNDER)</b>	SS (Stainless Steel)
<b>SPRING LOADING CAGE</b>	2

## ELECTRICAL

<b>POWER SUPPLY</b>	10 amp	
<b>FRIDGE MODELS</b>	<b>RUNNING AMPS</b>	4

## GAS TYPE

<b>REFRIGERANT</b>	<b>FRIDGE MODELS</b>	R134a
--------------------	----------------------	-------

\*\*\* For **OPTIONS** refer to the current Williams Price Guide