

NORRIS CAFEMATE AWC

code: 55-900-CB

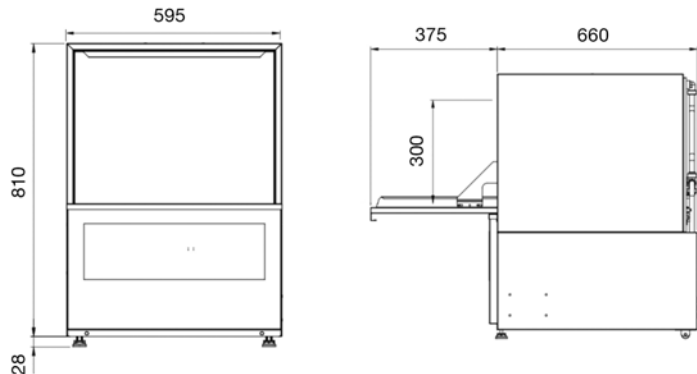

The Cafemate Advanced Wash Control model is a compact underbench dishwasher with a usable height capable of taking care of 30cm plates. Installation and superior cleaning is made easy with its standard pump out drain and detergent/rinse aid injectors.

FEATURES

- **Warranty** – 2 years parts and labour, 5 years on the cabinet & control board (see p.28 for conditions & extended warranty offer)
- Compact underbench dishwasher suited for cafes and small restaurants
- Cleans up to 600 plates per hour
- 1,2 & 5 minute wash cycle options
- Automatic detergent and rinse aid injection
- Separate rinse pump ensures a constant rinse regardless of incoming water pressure
- Fit standard with a drain pump allowing easy installation
- Rinse temperature accurately controlled by the thermostat function
- Rear rollers for easy inspection and cleaning
- Double skinned door reducing heat and noise pollution
- High grade stainless steel welded cabinet, wash arms and scrap trays for durability
- Australian made

INCLUSIONS

- 1 x Flat rack insert 500mm x 500mm
- 1 x Plate rack insert 500mm x 500mm
- 1 x Cutlery container
- 1 x Water connection hose
- 2 x Adjustable & 2 x Roller feet
- 2 x Chemical weights & filters
- 1 x Operating manual

TECHNICAL DATA

Height

Cabinet	810 mm
Cabinet inc. legs	838 mm
Usable Wash	300 mm

Width

Cabinet	595 mm
---------	--------

Depth

Cabinet	660 mm
With door open	1035 mm

Capacities

Loads/Hour	up to 30*
Water per Cycle	3L
Wash Pump	370W
Rinse Pump	310W
Wash Tank Litres	18
Rinse Tank Litres	10
Element (wash)	500W
Element (rinse)	2700W
Detergent Injection	yes
Rinse Aid Injection	yes

Temperatures

Wash Degrees C	62 °C
Rinse Degrees C	85 °C

Plumbing

Drain	Pump out
Water	½" BSP (hot)

Electrical

Volts/Hz	240V AC/50Hz
Max. Amp. load	15amps

Note: this machine has load shedding capability

* Subject to incoming water temperature