

## CF0700FTSS | Flat Top Stainless Steel 675L Chest Freezer

Chest Freezers

**CF0700FTSS**

**FLAT TOP  
STAINLESS STEEL  
675L CHEST  
FREEZER**

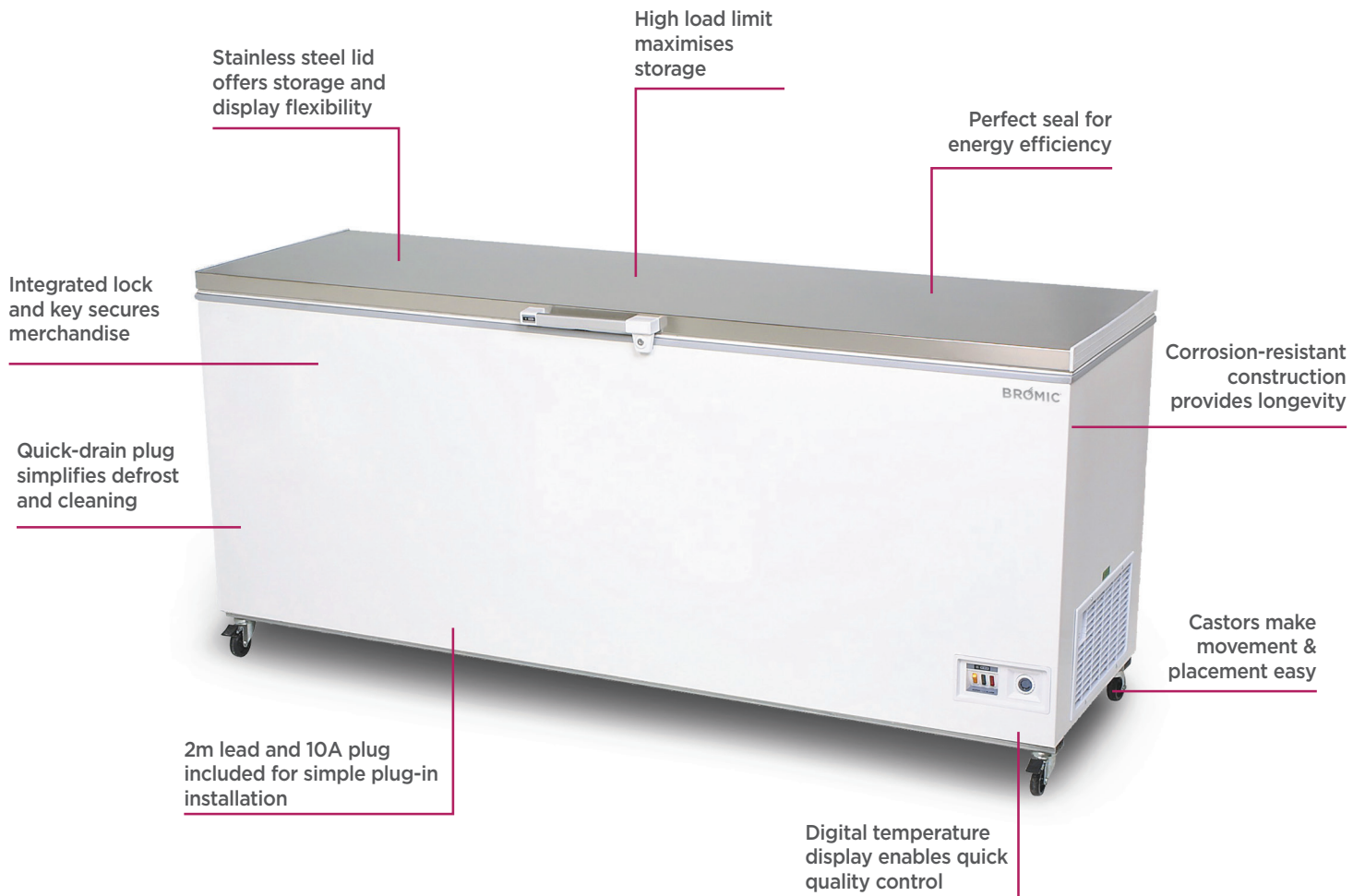

## CF0700FTSS | Flat Top Stainless Steel 675L Chest Freezer

### Chest Freezers

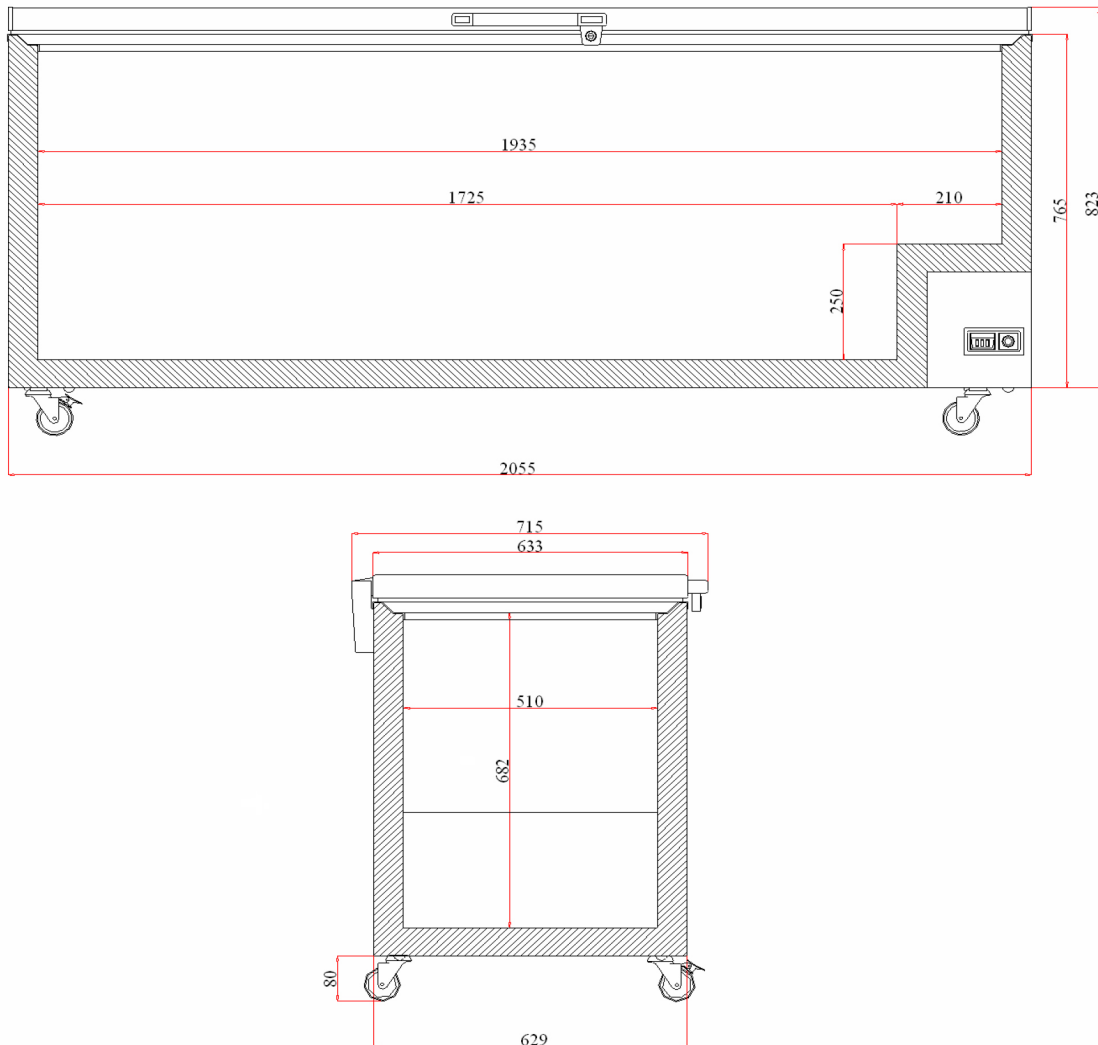

### SPECIFICATIONS

<b>Part Number</b>	3735306	<b>Internal Light</b>	No
<b>Capacity</b>	675L	<b>No. of Lids</b>	1
<b>Temperature range</b>	-25 to -15°C	<b>Lid Type</b>	Hinged - Stainless Steel
<b>Max. Ambient Temp</b>	35°C	<b>Total Height with lid open</b>	1618mm
<b>Refrigeration Capacity</b>	425W	<b>Lid Shape</b>	Flat
<b>Energy Consumption</b>	4.9kWh/24h	<b>Lid Lock</b>	Yes
<b>Current</b>	2.9A	<b>Temp. Controller</b>	Analogue controller, digital display
<b>Gross Weight</b>	119kg	<b>Castors</b>	Yes
<b>Packaged Dimensions</b>	2145 x 750 x 1005 mm	<b>No. Baskets Included</b>	3
<b>Air-Circulation</b>	Static	<b>Colour</b>	White
<b>Refrigerant</b>	R404a	<b>Warranty</b>	2 Years, Parts & Labour
<b>Plug Supplied</b>	Yes, 1 x 10A	<b>Warranty Service</b>	Bromic Extra Care
<b>Plug Location</b>	2m long, bottom right rear		

### DIMENSIONS

	External (mm)	Internal (mm)
<b>Width</b>	2055	1935
<b>Depth</b>	715	510
<b>Height</b>	903	682

All information is correct at the time of publication. BROMIC PTY Ltd reserve the right to alter specifications without notice.