

MADISON IM17

code: 25-000-2

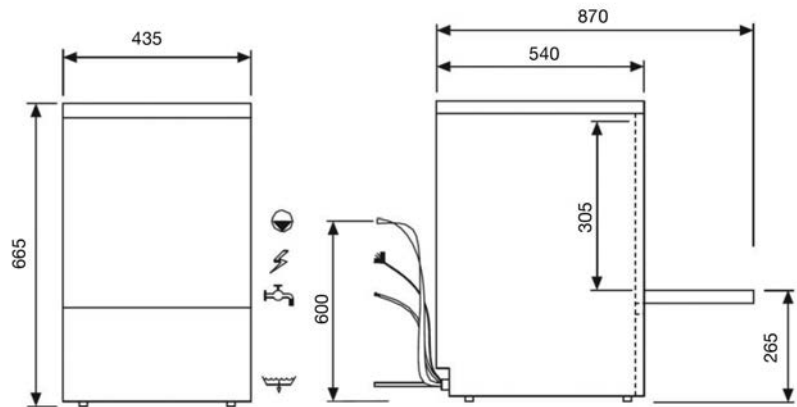

With European technologies specified to Norris' high standards for Australian conditions and demands, the IM17 commercial glasswasher will significantly lower your running cost. The electronic control system is based on the 'one button, one function operation' – simple and efficient. The technology in the IM17 glasswasher leaves other imported machines behind with better performance and considerable energy savings.

FEATURES

- **Warranty** – 1 year parts and labour, 3 years on the control board & cabinet (see p.28 for conditions & extended warranty offer)
- 60, 120 seconds wash cycle options
- Recycle wash system, using 2L per cycle
- Pump out drain
- Up to 800 glasses per hour*
- Automatic detergent injection
- Automatic rinse aid injection
- Automatic drain (no stem pipe)
- Double skinned door
- Easy clean pressed wash chamber
- Minimum rinse temperature cut out
- 15 amps
- High wash chamber

INCLUSIONS

- 1 x Wire glass rack insert 17"x14"
- 1 x Drain hose
- 1 x Water connection hose
- 1 x Operating manual

TECHNICAL DATA

Height

Cabinet	665 mm
Cabinet inc. legs	807 - 870 mm
Usable Wash	305 mm

Width

Cabinet	435 mm
---------	--------

Depth

Cabinet	540 mm
With door open	870 mm

Capacities

Loads/Hour	up to 30*
Water per Cycle	2L*
Wash Pump	300W
Wash Tank Litres	11
Boiler Tank Litres	2.6
Element (wash)	600W
Element (boiler)	2600W
Detergent Injection	yes
Rinse Aid Injection	yes

Temperatures

Wash Degrees C	60 °C
Rinse Degrees C	82 °C

Plumbing

Drain	Pump out
Water	¾" BSP (hot)

Electrical

Volts/Hz	240V AC/50Hz
Amps	15amps

* Subject to incoming water temperature + pressure



BUILT TO LAST

Water pressure requirements are: 10L/min at 200-400 kPa max.